

Surface Mount Schottky Barrier Rectifier

Features

- The plastic package carries Underwriters Laboratory Flammability Classification 94V-0
- For surface mounted applications
- Metal silicon junction, majority carrier conduction
- Low power loss, high efficiency
- Built-in strain relief, ideal for automated placement
- High forward surge current capability
- Lead free in comply with EU RoHS 2011/65/EU directives

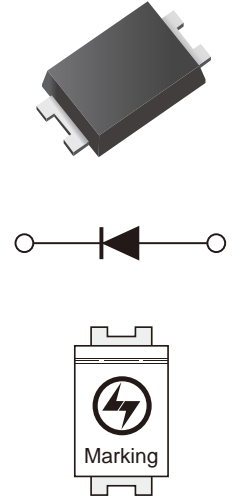

Mechanical Data

- Case: PDFN3620
- Terminal: Leads solderable per MIL-STD-750 Method 2026
- Polarity: Color band denotes cathode end
- Mounting Position: Any

Ordering Information

| Part Number | Shipping | Reel |
|---------------------|--------------------|-----------|
| LT22P3 THRU LT220P3 | 12000PCS Tape&Reel | 13 inches |

Maximum Ratings and Electrical Characteristics

Ratings at 25°C ambient temperature unless otherwise specified.
 Single phase half-wave 60Hz, resistive or inductive load, for capacitive load current derate by 20%.

| Parameter | Symbol | LT22P3 | LT24P3 | LT26P3 | LT28P3 | LT210P3 | LT212P3 | LT215P3 | LT220P3 | Unit |
|--|-----------------|-------------|--------|--------|----------|---------|---------|---------|---------|---------------|
| | Marking | P22 | P24 | P26 | P28 | P210 | P212 | P215 | P220 | |
| Maximum repetitive peak reverse voltage | V_{RRM} | 20 | 40 | 60 | 80 | 100 | 120 | 150 | 200 | V |
| Maximum RMS voltage | V_{RMS} | 14 | 28 | 42 | 56 | 70 | 84 | 105 | 140 | V |
| Maximum DC blocking voltage | V_{DC} | 20 | 40 | 60 | 80 | 100 | 120 | 150 | 200 | V |
| Maximum instantaneous forward voltage at 2A | V_F | 0.5 | 0.5 | 0.7 | 0.85 | 0.85 | 0.85 | 0.95 | 0.95 | V |
| Maximum average forward rectified current | $I_{(AV)}$ | 2 | | | | | | | | A |
| Peak forward surge current 8.3ms single half sine-wave superimposed on rated load (JEDEC Method) | I_{FSM} | 60 | | | | | | | | A |
| Maximum DC reverse current at rated DC reverse voltage $T_A=25^{\circ}C$ $T_A=100^{\circ}C$ | I_R | 0.15 5 | | | 0.3 3 | | | | mA | |
| Typical Junction Capacitance (Note1) | C_J | 220 | | | 80 | | | | pF | |
| Typical thermal resistance (Note2) | $R_{\theta JA}$ | 80 | | | | | | | | $^{\circ}C/W$ |
| Operating junction temperature range | T_J | -55 to +125 | | | | | | | | $^{\circ}C$ |
| Storage temperature range | T_{STG} | -55 to +150 | | | | | | | | $^{\circ}C$ |

Note: (1) Measured at 1MHz and applied reverse voltage of 4.0V D.C.

(2) P.C.B. mounted with 2.0" x 2.0" (5.0cm x 5.0cm) copper pad areas.



Characteristics Curve

FIG.1 FORWARD CURRENT DERATING CURVE

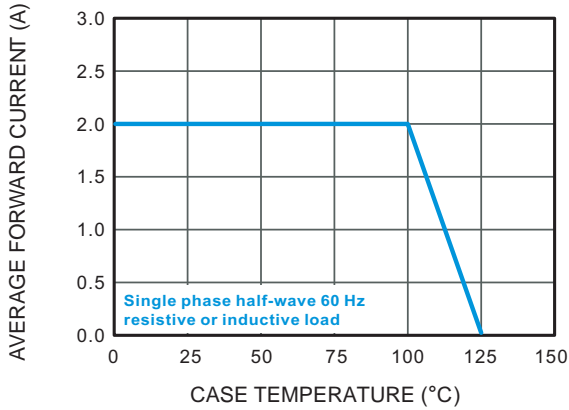

FIG.2 TYPICAL REVERSE CHARACTERISTICS

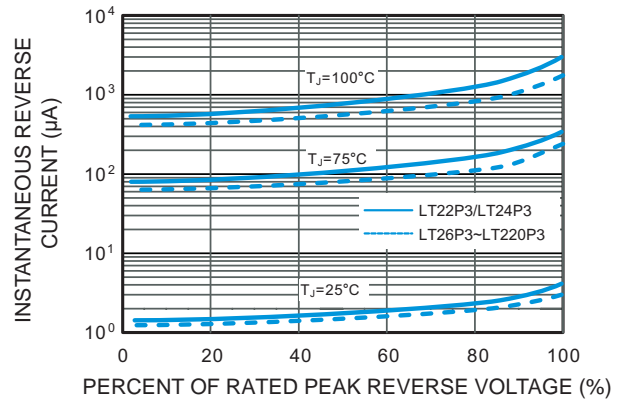

FIG.3 TYPICAL FORWARD CHARACTERISTICS

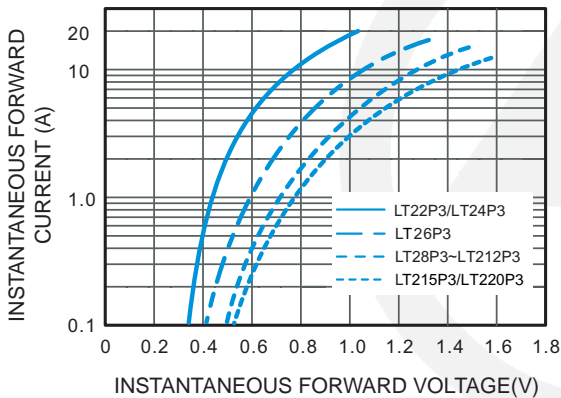

FIG.4 TYPICAL JUNCTION CAPACITANCE

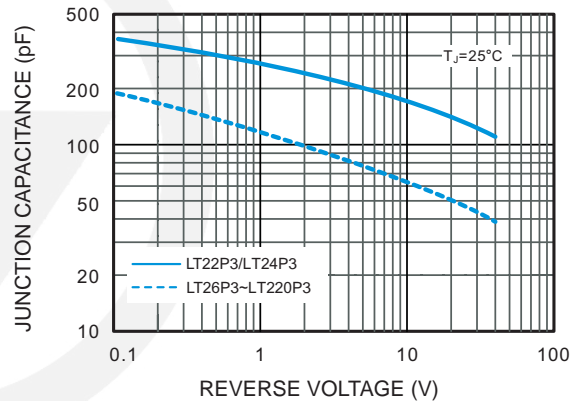

FIG.5 MAXIMUM NON-REPETITIVE PEAK FORWARD SURGE CURRENT

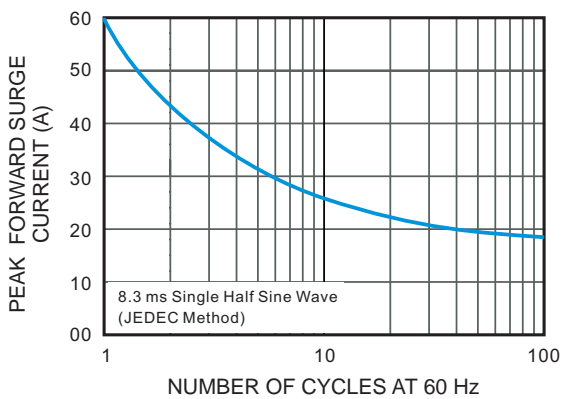
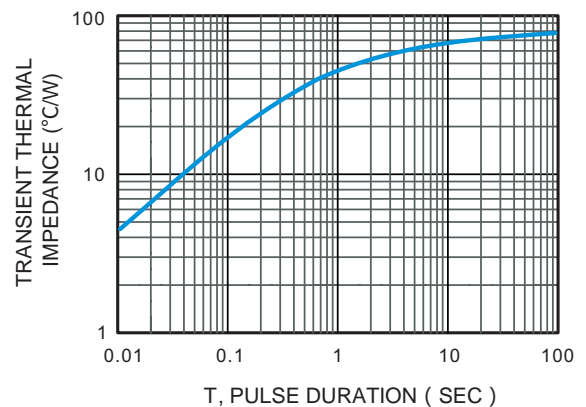
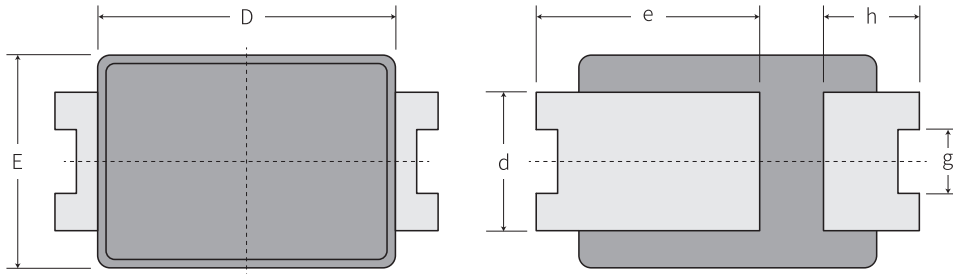

FIG.6 TYPICAL TRANSIENT THERMAL IMPEDANCE



Package Outline
PDFN3620
Unit : mm

Top View

Bottom View

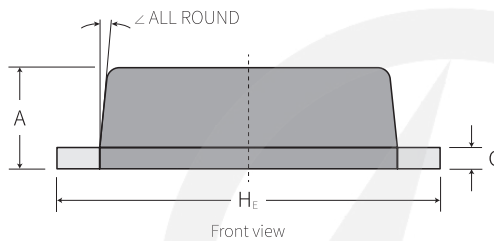

Front view

| UNIT | | A | C | D | E | H _E | d | e | g | h | ∠ |
|------|-----|------|------|------|------|----------------|------|------|------|------|----|
| mm | max | 1.15 | 0.30 | 3.00 | 2.20 | 3.80 | 1.50 | 2.30 | 0.80 | 1.10 | 6° |
| | min | 0.75 | 0.10 | 2.60 | 1.80 | 3.40 | 1.10 | 1.70 | 0.40 | 0.70 | |

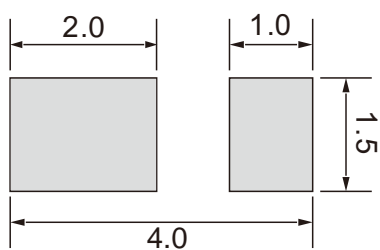
Suggested Pad Layout
PDFN3620
Unit : mm

Note:

1. Controlling dimension: in millimeters.
2. General tolerance: ± 0.05 mm
3. The pad layout is for reference purpose only.

Carrier Tape Dimensions

Unit : mm

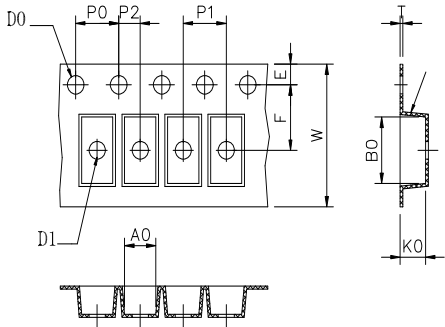

| Symbol | Spec | Symbol | Spec |
|--------|-----------|--------|-----------|
| W | 8.00±0.10 | P1 | 4.00±0.10 |
| E | 1.75±0.10 | P2 | 2.00±0.05 |
| F | 3.50±0.05 | T | 0.22±0.02 |
| D0 | 1.55±0.05 | A0 | 2.30±0.10 |
| D1 | 1.50±0.10 | B0 | 3.90±0.10 |
| P0 | 4.00±0.10 | K0 | 1.15±0.05 |

Reel Dimensions

Unit : mm

13" Reel

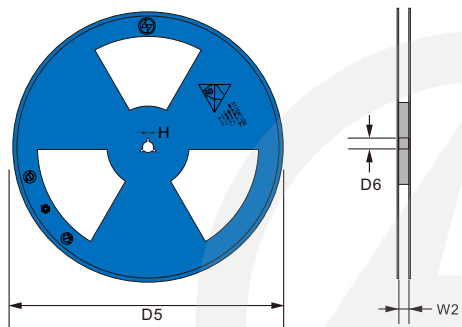

| | |
|--------------------|------------|
| D5 | Φ330.0±2.0 |
| D6 | Φ13.5±0.5 |
| H | 2.5±1.0 |
| W2 | 12±2.0 |
| Quantity: 12000PCS | |

Packaging

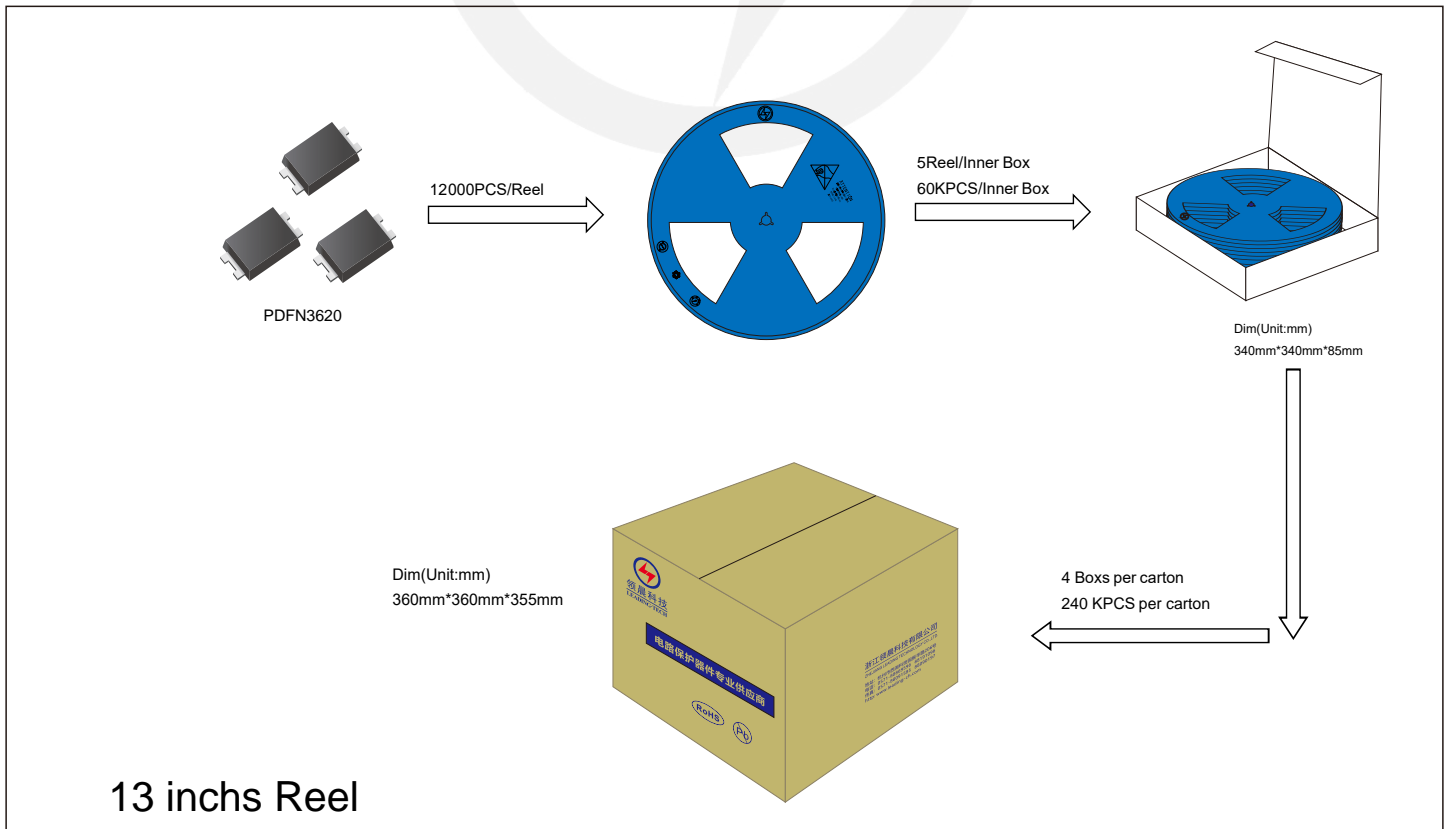



Recommended Soldering Conditions



Recommended Conditions

| Profile Feature | Pb-Free Assembly |
|--|------------------|
| Average ramp-up rate (T _L to T _P) | 3°C/second max. |
| Preheat | |
| -Temperature Min (T _{S min}) | 150°C |
| -Temperature Max (T _{S max}) | 200°C |
| -Time (min to max) (t _s) | 60-180 seconds |
| T _{S max} to T _L | |
| -Ramp-up Rate | 3°C/second max. |
| Time maintained above: | |
| -Temperature (T _L) | 217°C |
| -Time (t _L) | 60-150 seconds |
| Peak Temperature (T _P) | 260°C |
| Time within 5°C of actual Peak Temperature (t _p) | 20-40 seconds |
| Ramp-down Rate | 6°C/second max. |
| Time 25°C to Peak Temperature | 8 minutes max. |

Important Notice and Disclaimer

Leading-Tech reserves the right to make changes to this document and its products and specifications at any time without notice.

Customers should obtain and confirm the latest product information and specifications before final design, purchase or use.

Leading-Tech makes no warranty, representation or guarantee regarding the suitability of its products for any particular purpose, not does Leading-Tech assume any liability for application assistance or customer product design.

Leading-tech does not warrant or accept any liability with products which are purchase or used for any unintended or unauthorized application.

No license is granted by implication or otherwise under any intellectual property rights of Leading-Tech.

Leading-Tech products are not authorized for use as critical components in life support devices or systems without express written approval of Leading-tech.

Version Update Information

| Series NO. | Enactment/Revision Date | Effective Date | Version | Revision content | Revision Reason | Revision Person | Note |
|------------|-------------------------|----------------|---------|---|-----------------|-----------------|------|
| 01 | 2024.3.1 | 2024.3.1 | 1.0 | New File | / | Ding | |
| 02 | 2025.4.18 | 2025.4.18 | 1.1 | 1.Revise Marking 2.Package Outline e(min)=1.7 | / | Ding | |
| 03 | 2025.5.14 | 2025.5.14 | 1.2 | V _F Condition Corrected to 2A | / | Ding | |